

OUTDOOR ROLLER - BLINDS

Front window blind

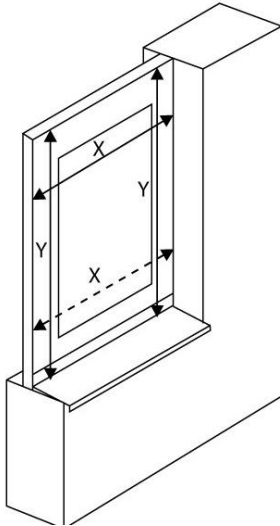

Under plaster blind

Height of the area for the location of the box. It is necessary to compare with the actual height of the box

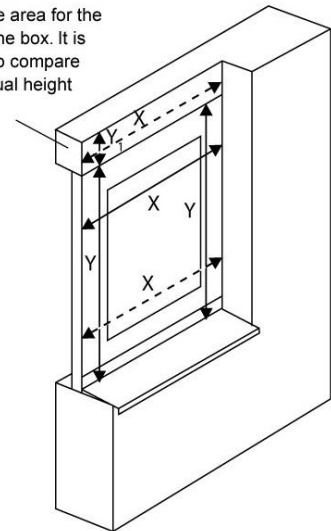

1. MEASUREMENTS OF THE STANDARD BLIND

THE ORDERING DIMENSIONS ARE THE DIMENSIONS OF THE FINISHED BLIND

Blind width = X (from the side edge of the guide rail to the edge of the other guide rail)

Blind height = Y (from the upper edge of the box to the lower edge of the guide rail)

The height and the width are always measured in a minimum of three places. The manufacturing dimensions are always the minimum measured value. Measurements are taken after the frame or window is fitted into the construction hole after completion of the outside and inside reveals, including parapets. The method of measurement of outdoor blinds is so specific that it is recommended to consult the technical plans at the construction site. Other specific solutions are possible.

2. ASSEMBLY

The assembly may only be performed by a qualified professional employee!

Construction preparedness for the assembly: finished reveal, coloured façade, finished outside parapets

AREA FOR ASSEMBLY

- on the top 5 - 10 mm (closed with sealing substance) - the gap between the edge of the box and the lintel
- on sides also approximately 5 mm - the gap between the side edge of the guide rail and the scuncheon
- down: leave a maximum distance of 5 mm between the leading bar and the parapet

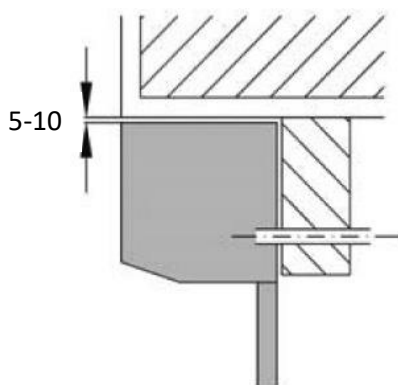

Assembly into the façade

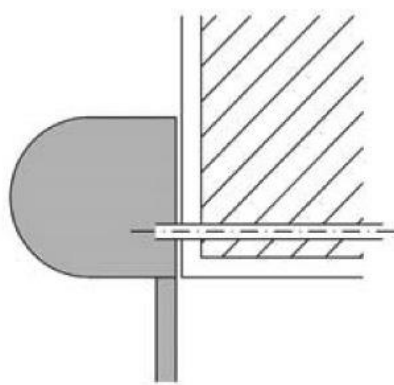

Assembly on the facade

INSPECTION:

- Before assembly we recommend inspecting all the parts after delivery of the goods to prevent any problems. The manufacturer must be notified of any defects or comments concerning the assembly or blinds.

BASIC TYPES OF ASSEMBLY:

ASSEMBLY PROCEDURE:

1. Check the dimensions of the blind and the construction hole or the window

2. On the box cut the outlet for the strip, cable or lever of the conical gearbox and drill the passage on the wall or in the window. To prevent damage to the strip, it is necessary to drill the passage for the strip perpendicularly,

if possible. Pay attention when drilling to the handle bar; the square must be located centrally in the drilled hole and must not be in contact with the walls in the hole and the scrub in them. (For the 14 mm strip, drill about 16 mm / for the cable, drill a hole about 10 mm / for the conical gearbox, follow the manual).

3. Insert the guiding bars into the leg of the side wall; check the guiding bars are the same height. (The insertion of the guiding bar into the side wall must not damage the starting point of the armour located in the side wall.)

4. Marking of drilling points in which the screws fix the blind (the size is according to the masonry and screws used).

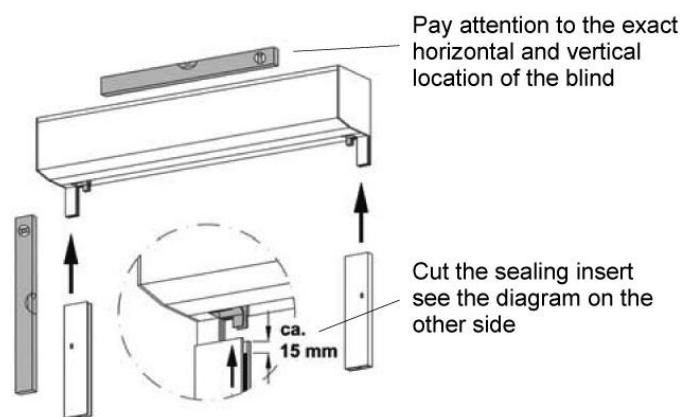

In the upper part of the guide rail, there is a fixing hole for additional fixing of the box, which it prevents it from tipping over.

CONTROL USING THE STRIP OR THE CORD

5. On the strip attach the penetration, plastic tube, tape roll, etc. (roll downward, brush upward).

6. Suspend the strip or the cord into the spring clamp so that during the movement of the armour the upward strip is automatically wound into the winding mechanism (according to the construction the winding mechanism must be open and the strip must be hooked and fixed to the spring mechanism).

We advise that when shortening the strip, the blind armour must be lowered. When working with the strip, the spring mechanism must be secured against winding!

7. Fixation of the winding mechanism on the frame of the window or the wall.

8. Fixing a tape or cord grommet on a wall or window frame (the roll simplifies the movement of the strip).

ENGINE CONTROL

9. Attach the cable from the engine to the connection box.

It is necessary to connect the motor cables according to the drawing from the supplier and must be carried out by trained professionals. The entire electrical line must be de-energized during connection. The motors are in the factory settings, and during assembly it is necessary to perform the settings according to the manufacturer's instructions, including the end stops.

ATTENTION! The lower end position must never be exceeded. This could lead to reverse winding of the fabric and damage to the roller shutter.

CONTROL BY HANDLE:

10. Pushing through the wall or frame of the square articulated bearing and fastening to the bevel gearbox (in the box, the square must be shortened depending on the version).

11. Fixation of the joint bearing by the attached screws on the wall or the window frame.

12. Insert the handle (profiled tube) into the joint bearing and fix it with the fixation clamp (plastic ring).

13. Fixation of the handle holder on the window frame or the wall.

14. Version of the box under the plaster:

- Before starting plaster work it is necessary to cover the joints between the box and the wall and the large area joint. (Additional fixation and armouring prevents the origination of cracks from tension.)
- When installing the plastering boxes, you must follow the plastering guidelines, or consult a plastering company. In principle, the box must be fixed to the masonry with the supplied perforated fastening tapes or similar fastening means. The following should be observed: the screw for fixing the perforated tape should be screwed into the upper part of the box as far as possible to avoid damage to the hinge inside the box.

TYPES OF MOUNTING OF THE GUIDE RAILS

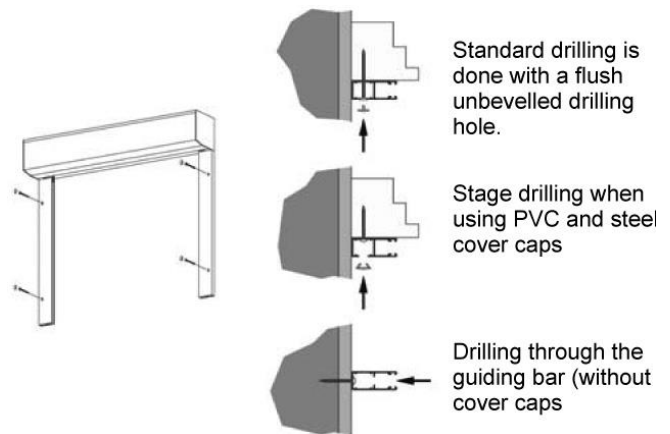

- Fixing strap for flush-mounted boxes, abbreviation 2: PR0511, can be selected as an optional accessory.

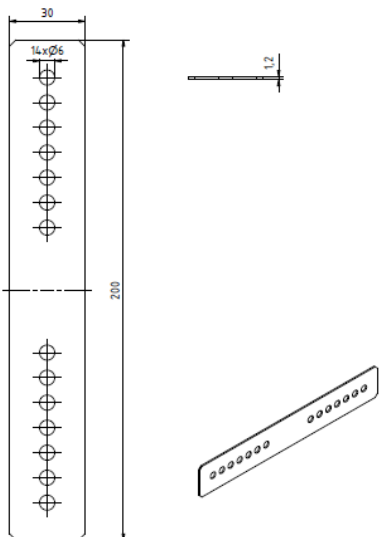

NUMBER OF FIXATIONS FOR ONE GUIDING BAR:

Height of the blind up to 150 cm > 2 fixation points in one guiding bar

Height of the blind up to 150 cm > 3 fixation points in one guiding bar

Height of the blind 250 cm > 4 fixation points in one guiding bar

This data is valid during assembly into the masonry with a sufficient load-bearing capacity. The same is also valid for data for the attached joining material. The fixation material must be chosen according to the strength of the masonry and the static conditions of the particular case.

Guiding rails drilling (A)from the side AXb, B)face side AX)

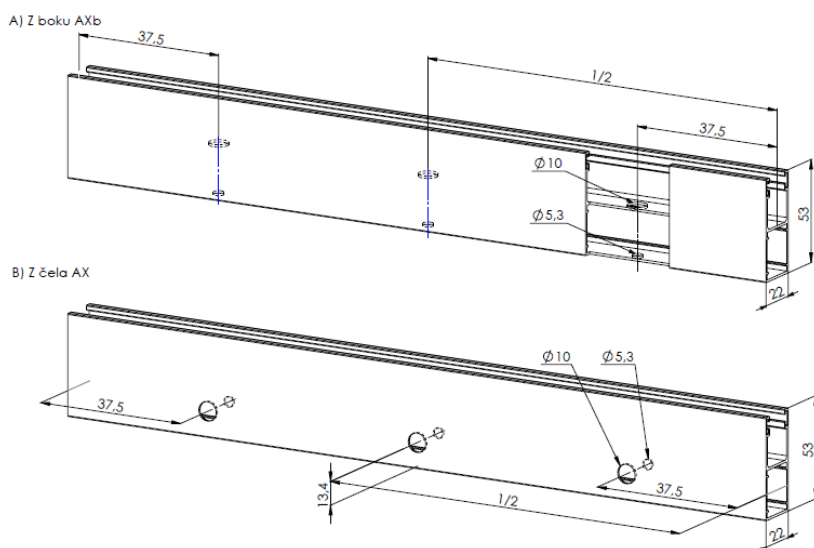

To prevent hooking the blind armour when starting:

The sealing insert of the guiding bar in the upper part of the starting position about 15 mm from the upper edge must be cut. (Before assembly of the guiding bars!)

Dismantling of the revision cover of the box must always be enabled. Therefore, the revision cover cannot be plastered or fixed into the construction. For the installation of boxes under the plaster, the strip is prepared which is fixed to the side by the rivet which can be plastered.

approximately 15 mm

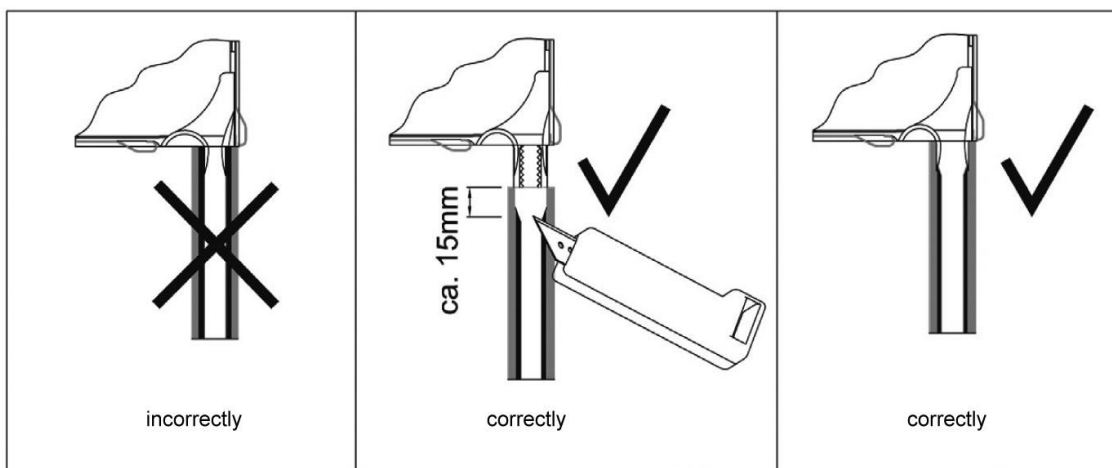

NORMA EN 13659 – Control Force Limitation for Manual Control

The roller blind armoring weight depends on the slat weight values (kg per m²) and the total roller blind area (m²)

Use of slat	m ²	M 317; M 328; MY 442											M317; MY442		MY 442			
		0,5	1,0	1,5	2,0	2,5	3,0	3,5	4,0	4,5	5,0	5,5	6,0	6,5	7,0	7,5	8,0	8,5
Slat type	kg/m ²	roller blind armoring weight (kg)*																
M317	2,80	1	3	4	6	7	8	10	11	13	14	15	17	18				
M 328	2,60	1	3	4	5	7	8	9	10	12	13	14						
MY 442	3,45	2	3	5	7	9	10	12	14	16	17	19	21	22	24	26	28	29

*the roller blind armoring weight is rounded!

Control	Maximum armoring weight (kg)
tape	9
cord	5
winder with crank tape/cord	9
crank	15

Selection of control type based on roller blind armoring weight (kg)

		0,5	1,0	1,5	2,0	2,5	3,0	3,5	4,0	4,5	5,0	5,5	6,0	6,5	7,0	7,5	8,0	8,5	
Slat type	kg/m²	roller blind armoring weight (kg)*																	
M317	2,80	6	6	6	1,3,4,5	1,3,4,5	1,3,4,5	4,5	4,5	4,5	4,5	4,5	5	5					
M 328	2,60	6	6	6	6	1,3,4,5	1,3,4,5	1,3,4,5	4,5	4,5	4,5	4,5							
MY 442	3,45	6	6	6	1,3,4,5	1,3,4,5	4,5	4,5	4,5	5	5	5	5	5	5	5	5	5	5

Explanatory notes

tape	1
cord	2
winder with tape/cord	3
crank	4
motor	5
all control types	6